

Zertifikat

Für das Objekt

Schönfelder Straße 50, 54298 Orenhofen

wurde am 02.07.2026 eine Flächenberechnung durchgeführt.

Die ermittelte Fläche nach der aktuellen Wohnflächenverordnung (WoFIV) beträgt:

311,17 m² Wohnfläche
218,85 m² Nutzfläche

Die Berechnung wurde von staatlich geprüften Vermessungsingenieuren und -technikern durchgeführt.

Die Richtigkeit der Flächenberechnung bestätigen:



Diplom-Ingenieur & Architekt
Hans-Jörg Broda



i.A ALPHA Software GmbH
Architectural Designer
Laurenz Hesse

Verfasserdaten

ALPHA Software GmbH - Lennard Meder - Tizianstraße 1a, 14467 Potsdam

Berechnung der Wohnfläche

gemäß "Verordnung zur Berechnung der Wohnfläche" vom 01.01.2004 (WoFIV)

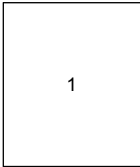
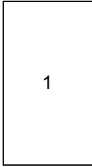
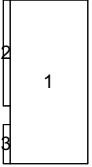
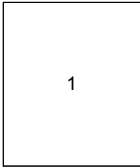
Berechnung			
Nr.	Raumbeschreibung	Fläche [m²]	Von den Behörden auszufüllen Überbaute Fläche [m²]
			Zu berechnende Fläche [m²]
05	UG Schlafen		17,51
		<p style="text-align: right;">Fläche</p> <p>1: $3,84 * 4,56 = 17,51$</p> <p>Summe: 17,51</p> <p>Rundungskorrektur: 0,00</p>	
06	UG Home-Office		11,35
		<p style="text-align: right;">Fläche</p> <p>1: $2,49 * 4,56 = 11,35$</p> <p>Summe: 11,35</p> <p>Rundungskorrektur: 0,00</p>	
07	UG Küche		9,54
		<p style="text-align: right;">Fläche</p> <p>1: $2,05 * 4,32 = 8,86$</p> <p>2: $0,18 * 2,79 = 0,50$</p> <p>3: $0,18 * 1,03 = 0,19$</p> <p>Summe: 9,55</p> <p>Rundungskorrektur: -0,01</p>	
08	UG Wohnzimmer		15,70
		<p style="text-align: right;">Fläche</p> <p>1: $3,64 * 4,32 = 15,72$</p> <p>Summe: 15,72</p> <p>Rundungskorrektur: -0,02</p>	

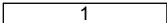
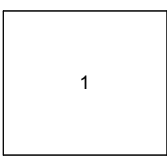
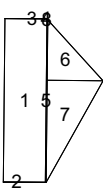
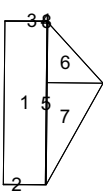
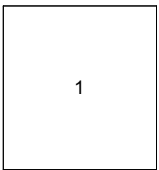

Schönfelder Straße 50, 54298 Orenhofen

09	UG Gang		14,26
		<p style="text-align: right;">Fläche</p> <p>1: $10,26 * 1,39 = 14,26$</p> <p>Summe: 14,26</p> <p>Rundungskorrektur: 0,00</p>	
10	UG Bad		7,56
		<p style="text-align: right;">Fläche</p> <p>1: $2,93 * 2,58 = 7,56$</p> <p>Summe: 7,56</p> <p>Rundungskorrektur: 0,00</p>	
16	UG Terrasse		6,09
 		<p style="text-align: right;">Fläche</p> <p>1: $1,93 * 7,50 = 14,48$</p> <p>2: $1,93 * 0,02 / 2 = 0,02$</p> <p>3: $1,91 * 0,02 / 2 = 0,02$</p> <p>4: $0,02 * 0,02 / 2 = 0,00$</p> <p>5: $7,46 * 0,04 = 0,30$</p> <p>6: $2,57 * 2,77 / 2 = 3,56$</p> <p>7: $2,57 * 4,69 / 2 = 6,03$</p> <p>8: $0,04 * 0,04 / 2 = 0,00$</p> <p>Summe: 24,41</p> <p style="text-align: right;">Schraffurabzug</p> <p>1: $1,93 * 7,50 = 14,48$</p> <p>2: $1,93 * 0,02 / 2 = 0,02$</p> <p>3: $1,91 * 0,02 / 2 = 0,02$</p> <p>4: $0,02 * 0,02 / 2 = 0,00$</p> <p>5: $7,46 * 0,04 = 0,30$</p> <p>6: $2,57 * 2,77 / 2 = 3,56$</p> <p>7: $2,57 * 4,69 / 2 = 6,03$</p> <p>8: $0,04 * 0,04 / 2 = 0,00$</p> <p>Summe (75%): 18,31</p> <p>Rundungskorrektur: -0,01</p>	
18	EG Schlafen		20,50
		<p style="text-align: right;">Fläche</p> <p>1: $4,38 * 4,68 = 20,50$</p> <p>Summe: 20,50</p> <p>Rundungskorrektur: 0,00</p>	

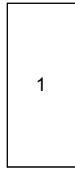
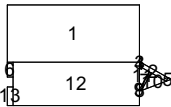
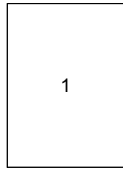
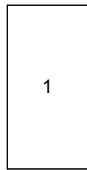
Schönfelder Straße 50, 54298 Orenhofen

19	EG Ankleidezimmer		9,17
		Fläche	
		1: $1,96 * 4,68$	= 9,17
		Summe:	9,17
		Rundungskorrektur:	0,00
20	EG Wohnen/Essen		47,04
		Fläche	
		1: $7,74 * 3,35$	= 25,93
		2: $1,79 * 0,24$	= 0,43
		3: $0,12 * 0,03 / 2$	= 0,00
		4: $0,12 * 0,21 / 2$	= 0,01
		5: $0,20 * 0,24 / 2$	= 0,02
		6: $0,34 * 0,87$	= 0,30
		7: $1,19 * 0,12$	= 0,14
		8: $0,08 * 0,08 / 2$	= 0,00
		9: $0,04 * 0,08 / 2$	= 0,00
		10: $0,99 * 1,19 / 2$	= 0,59
		11: $0,67 * 1,19 / 2$	= 0,40
		12: $7,40 * 2,54$	= 18,80
		13: $0,34 * 1,09$	= 0,37
		Summe:	46,99
		Rundungskorrektur:	0,05
21	EG Küche		12,71
		Fläche	
		1: $3,02 * 4,21$	= 12,71
		Summe:	12,71
		Rundungskorrektur:	0,00
22	EG Spk.		3,41
		Fläche	
		1: $1,30 * 2,62$	= 3,41
		Summe:	3,41
		Rundungskorrektur:	0,00

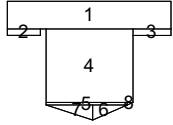
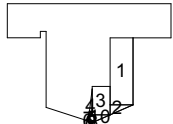
Schönfelder Straße 50, 54298 Orenhofen

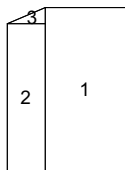
23	EG Flur	16,79	
 		<p style="text-align: center;">Fläche</p> <p>1: $6,74 * 1,14$ = 7,68 2: $1,36 * 0,26$ = 0,35 3: $1,56 * 0,27$ = 0,42 4: $3,58 * 3,02$ = 10,81 5: $3,34 * 0,11$ = 0,37 6: $1,42 * 0,62 / 2$ = 0,44 7: $1,92 * 0,62 / 2$ = 0,60 8: $0,24 * 0,11 / 2$ = 0,01</p> <p>Summe: 20,68</p> <p style="text-align: center;">Schraffurabzug</p> <p>1: $0,94 * 2,76$ = 2,59 2: $0,94 * 0,41 / 2$ = 0,19 3: $0,74 * 1,17$ = 0,87 4: $0,13 * 1,07 / 2$ = 0,07 5: $0,26 * 0,26$ = 0,07 6: $0,03 * 0,01 / 2$ = 0,00 7: $0,03 * 0,25 / 2$ = 0,00 8: $0,11 * 0,05 / 2$ = 0,00 9: $0,15 * 0,05 / 2$ = 0,00 10: $0,60 * 0,26 / 2$ = 0,08</p> <p>Summe (100%) 3,87</p> <p>Rundungskorrektur: -0,02</p>	
25	EG G-WC	3,41	
		<p style="text-align: center;">Fläche</p> <p>1: $1,36 * 2,51$ = 3,41</p> <p>Summe: 3,41</p> <p>Rundungskorrektur: 0,00</p>	
26	EG Bad	11,54	
		<p style="text-align: center;">Fläche</p> <p>1: $1,98 * 4,03$ = 7,98 2: $0,93 * 3,63$ = 3,38 3: $0,93 * 0,40 / 2$ = 0,19</p> <p>Summe: 11,55</p> <p>Rundungskorrektur: -0,01</p>	

Schönfelder Straße 50, 54298 Orenhofen

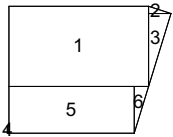
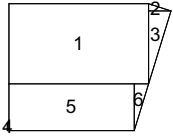
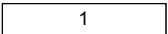
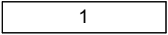

27	EG Terrasse	4,06	
 		<p style="text-align: right;">Fläche</p> <p>1: $4,16 * 2,39$ = 9,94 2: $0,67 * 0,22 / 2$ = 0,07 3: $0,67 * 2,17 / 2$ = 0,73 4: $0,05 * 0,22$ = 0,01 5: $3,73 * 1,39$ = 5,18 6: $0,43 * 1,39 / 2$ = 0,30</p> <p>Summe: 16,23</p> <p style="text-align: right;">Schraffurabzug</p> <p>1: $4,16 * 2,39$ = 9,94 2: $0,67 * 0,22 / 2$ = 0,07 3: $0,67 * 2,17 / 2$ = 0,73 4: $0,05 * 0,22$ = 0,01 5: $3,73 * 1,39$ = 5,18 6: $0,43 * 1,39 / 2$ = 0,30</p> <p>Summe (75%) 12,17 Rundungskorrektur: 0,00</p>	
35	EG Balkon	2,06	
 		<p style="text-align: right;">Fläche</p> <p>1: $6,59 * 1,25$ = 8,24</p> <p>Summe: 8,24</p> <p style="text-align: right;">Schraffurabzug</p> <p>1: $6,59 * 1,25$ = 8,24</p> <p>Summe (75%) 6,18 Rundungskorrektur: 0,00</p>	
Summe Wohnfläche [m²]		212,70	

Berechnung der Wohnfläche

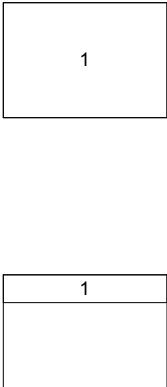
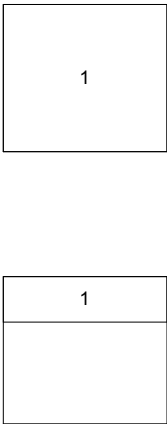
gemäß "Verordnung zur Berechnung der Wohnfläche" vom 01.01.2004 (WoFIV)

Berechnung			
Nr.	Raumbeschreibung	Fläche [m²]	Von den Behörden auszufüllen Überbaute Fläche [m²]
			Zu berechnende Fläche [m²]
30	DG Schlafen		25,69
	<div style="text-align: center;">  </div>	<p style="text-align: right;">Fläche</p> <p>1: $6,45 * 4,53 = 29,22$</p> <p>Summe: 29,22</p> <p style="text-align: right;">Schraffurabzug</p> <p>1: $6,45 * 1,10 = 7,10$</p> <p>Summe (50%) 3,55</p> <p>Rundungskorrektur: 0,02</p>	
31	DG Wohnen		33,52
	<div style="text-align: center;">  </div>	<p style="text-align: right;">Fläche</p> <p>1: $6,64 * 5,97 = 39,64$</p> <p>Summe: 39,64</p> <p style="text-align: right;">Schraffurabzug</p> <p>1: $6,64 * 1,84 = 12,22$</p> <p>Summe (50%) 6,11</p> <p>Rundungskorrektur: -0,01</p>	

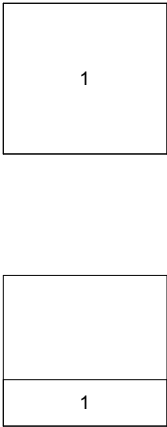
Schönfelder Straße 50, 54298 Orenhofen

32	DG Küche	15,08	
		<p style="text-align: right;">Fläche</p> <p>1: 4,40 * 4,05 = 17,82</p> <p>Summe: 17,82</p> <p style="text-align: right;">Schraffurabzug</p> <p>1: 4,40 * 1,25 = 5,50</p> <p>Summe (50%): 2,75</p> <p>Rundungskorrektur: 0,01</p>	
33	DG Diele	10,59	
		<p style="text-align: right;">Fläche</p> <p>1: 2,69 * 5,27 = 14,18</p> <p>2: 0,83 * 0,80 / 2 = 0,33</p> <p>3: 1,86 * 0,80 / 2 = 0,74</p> <p>4: 1,12 * 4,18 = 4,68</p> <p>5: 1,12 * 1,09 / 2 = 0,61</p> <p>Summe: 20,54</p> <p style="text-align: right;">Schraffurabzug</p> <p>1: 1,20 * 2,63 = 3,16</p> <p>2: 1,20 * 1,16 / 2 = 0,70</p> <p>3: 0,10 * 1,29 = 0,13</p> <p>4: 0,10 * 0,10 / 2 = 0,01</p> <p>5: 0,43 * 2,01 = 0,86</p> <p>6: 2,51 * 1,61 = 4,04</p> <p>7: 2,11 * 0,17 = 0,36</p> <p>8: 0,65 * 0,63 / 2 = 0,20</p> <p>9: 1,46 * 0,63 / 2 = 0,46</p> <p>10: 0,40 * 0,17 / 2 = 0,03</p> <p>Summe (100%): 9,95</p> <p>Rundungskorrektur: 0,00</p>	

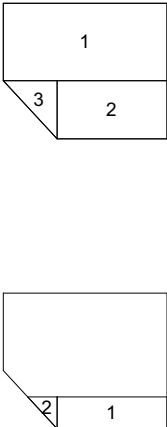

Schönfelder Straße 50, 54298 Orenhofen

34	DG Bad	13,59	
		<p style="text-align: right;">Fläche</p> <p>1: $4,42 * 2,09$ = 9,24 2: $2,97 * 1,57$ = 4,66 3: $1,45 * 1,57 / 2$ = 1,14</p> <p>Summe: 15,04</p> <p style="text-align: right;">Schraffurabzug</p> <p>1: $2,97 * 0,86$ = 2,55 2: $0,79 * 0,86 / 2$ = 0,34</p> <p>Summe (50%) 1,45 Rundungskorrektur: 0,00</p>	
Summe Wohnfläche [m²]		98,47	

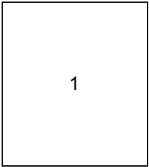
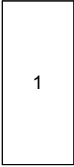
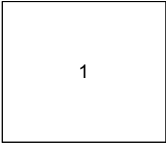
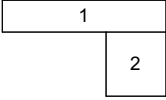
Summe Nutzfläche

Berechnung			
Nr.	Raumbeschreibung	Fläche [m²]	Von den Behörden auszufüllen Überbaute Fläche [m²]
			Zu berechnende Fläche [m²]
01	UG Werkstatt		37,26
		<p style="text-align: right;">Fläche</p> <p>1: $5,75 * 6,48 = 37,26$</p> <p>Summe: 37,26</p> <p>Rundungskorrektur: 0,00</p>	
02	UG Heizöl		1,98
		<p style="text-align: right;">Fläche</p> <p>1: $0,93 * 2,13 = 1,98$</p> <p>Summe: 1,98</p> <p>Rundungskorrektur: 0,00</p>	
03	UG Warmwasser		5,26
		<p style="text-align: right;">Fläche</p> <p>1: $2,47 * 2,13 = 5,26$</p> <p>Summe: 5,26</p> <p>Rundungskorrektur: 0,00</p>	
04	UG Keller		10,91
		<p style="text-align: right;">Fläche</p> <p>1: $5,68 * 1,11 = 6,30$</p> <p>2: $2,08 * 2,22 = 4,62$</p> <p>Summe: 10,92</p> <p>Rundungskorrektur: -0,01</p>	

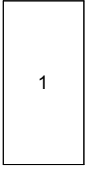
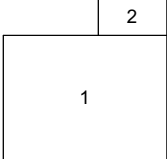
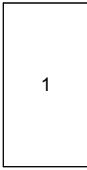
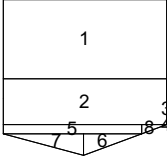
Schönfelder Straße 50, 54298 Orenhofen

11	UG Abstell-raum		3,28
		<p>Fläche</p> <p>1: $1,27 * 2,58 = 3,28$</p> <p>Summe: 3,28</p> <p>Rundungskorrektur: 0,00</p>	
12	UG Waschküche		5,63
		<p>Fläche</p> <p>1: $2,55 * 1,96 = 5,00$</p> <p>2: $1,07 * 0,59 = 0,63$</p> <p>Summe: 5,63</p> <p>Rundungskorrektur: 0,00</p>	
13	UG Flur		2,02
		<p>Fläche</p> <p>1: $1,03 * 1,96 = 2,02$</p> <p>Summe: 2,02</p> <p>Rundungskorrektur: 0,00</p>	
14	UG Diele		12,62
		<p>Fläche</p> <p>1: $3,80 * 1,84 = 6,99$</p> <p>2: $3,80 * 1,07 = 4,07$</p> <p>3: $0,01 * 1,06 / 2 = 0,01$</p> <p>4: $0,01 * 0,00 / 2 = 0,00$</p> <p>5: $3,22 * 0,21 = 0,68$</p> <p>6: $1,35 * 0,50 / 2 = 0,34$</p> <p>7: $1,87 * 0,50 / 2 = 0,47$</p> <p>8: $0,58 * 0,21 / 2 = 0,06$</p> <p>Summe: 12,62</p> <p>Rundungskorrektur: 0,00</p>	
15	UG Öl-Heizung		4,85
		<p>Fläche</p> <p>1: $2,45 * 1,98 = 4,85$</p> <p>Summe: 4,85</p> <p>Rundungskorrektur: 0,00</p>	

Schönfelder Straße 50, 54298 Orenhofen

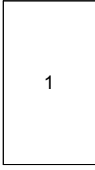
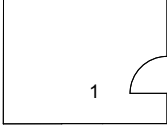
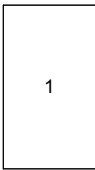
17	EG Garage		60,72
		Fläche	
		1: $5,85 * 10,38$	= 60,72
		Summe:	60,72
		Rundungskorrektur:	0,00
28	EG Gartenhaus		11,63
		Fläche	
		1: nicht partitioniert	= 11,63
		Summe:	11,63
		Rundungskorrektur:	0,00
29	DG Dachboden		62,69
		Fläche	
		1: $5,97 * 10,50$	= 62,69
		Summe:	62,69
		Rundungskorrektur:	0,00
Summe Nutzfläche			218,85

Berechnung Kubatur

Berechnung (basierend auf einem CAD-Modell)

	Höhe [m]	Brutto-Grundfläche R [m ²]	Brutto-Grundfläche S [m ²]	Brutto-Volumen R [m ³]	Brutto-Volumen S [m ³]
-1. KG					
UG	2,60	193,49		503,07	
Summe -1. KG		193,49	0,00	503,07	0,00
0. EG					
EG	2,60	215,24		559,63	
Summe 0. EG		215,24	0,00	559,63	0,00
1. OG					
OG	2,60	201,69		524,39	
Summe 1. OG		201,69	0,00	524,39	0,00

	Brutto-Grundfläche R [m ²]	Brutto-Grundfläche S [m ²]	Brutto-Volumen R [m ³]	Brutto-Volumen S [m ³]
-1. KG	193,49	0,00	503,07	0,00
0. EG	215,24	0,00	559,63	0,00
1. OG	201,69	0,00	524,39	0,00
Gesamtsumme	610,42	0,00	1587,09	0,00

Brutto-Grundfläche R+S [m²]	610,42
Brutto-Volumen R+S [m³]	1587,09



Nutzfläche



Gewerbefläche



Wohnfläche



0% angerechnete Fläche nach WoFIV



50% angerechnete Fläche nach WoFIV



25% angerechnete Fläche nach WoFIV

Architekt
Dipl.-Ing. & Architekt Hans-Jörg Broda
Heusteigstraße 76/1
70180 Stuttgart



Gebäudeart: Einfamilienhaus mit Einliegerwohnung

Adresse: Schönfelder Straße 50, 54298 Orenhofen

Planinhalt: EG

Firma:

Maßstab:
M 1:150

Layout:
A4

Datum:
02.07.2026





Nutzfläche



Gewerbefläche



Wohnfläche



0% angerechnete Fläche nach WoFIV



50% angerechnete Fläche nach WoFIV



25% angerechnete Fläche nach WoFIV

Architekt
 Dipl.-Ing. & Architekt Hans-Jörg Broda
 Heusteigstraße 76/1
 70180 Stuttgart



Gebäudeart: Einfamilienhaus mit Einliegerwohnung

Adresse: Schönfelder Straße 50, 54298 Orenhofen

Planinhalt: EG

Firma:

Maßstab:
 M 1:150

Layout:
 A4

Datum:
 02.07.2026



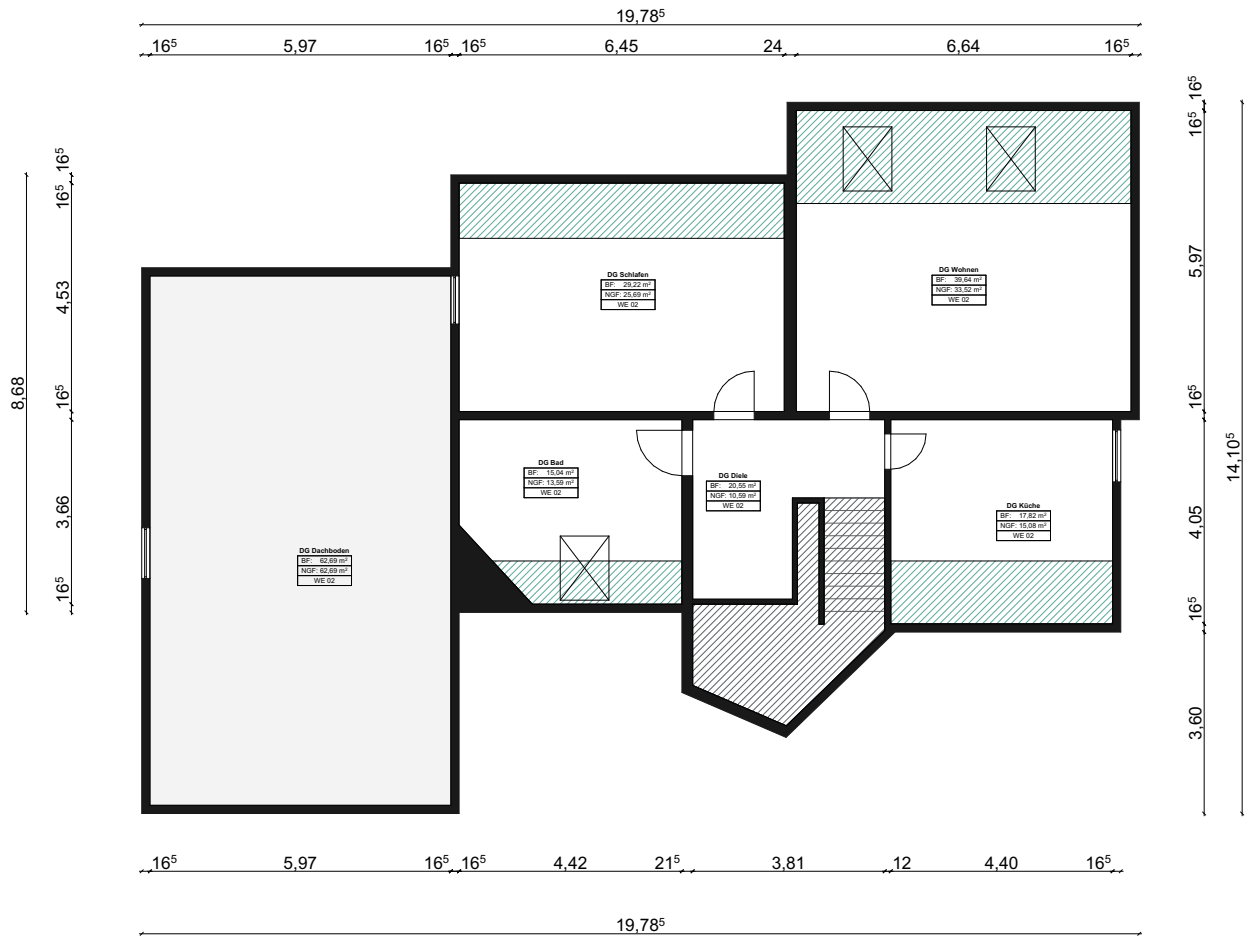

Nutzfläche



Gewerbefläche



Wohnfläche



0% angerechnete Fläche nach WoFIV



50% angerechnete Fläche nach WoFIV



25% angerechnete Fläche nach WoFIV

Architekt
Dipl.-ing. & Architekt Hans-Jörg Broda
Heusteigstraße 76/1
70180 Stuttgart



Gebäudeart: Einfamilienhaus mit Einliegerwohnung

Adresse: Schönfelder Straße 50, 54298 Orenhofen

Planinhalt: DG

Firma:

Maßstab:
M 1:150

Layout:
A4

Datum:
02.07.2026

